

# Hydraulic/step type

## HLH Low Platform

Load capacity: 221/441 lb

Wide lifting and lowering stroke. Equipped with wheels for easy movement.

A lifter with many applications only limited by your imagination.

### Major features of the HLH Series

- Hydraulic cylinder
- Casters with brakes
- Foot pedal type
- Overloading prevention device
- Nose dive prevention valve (HLH-100-80L only)



HLH-100-80L

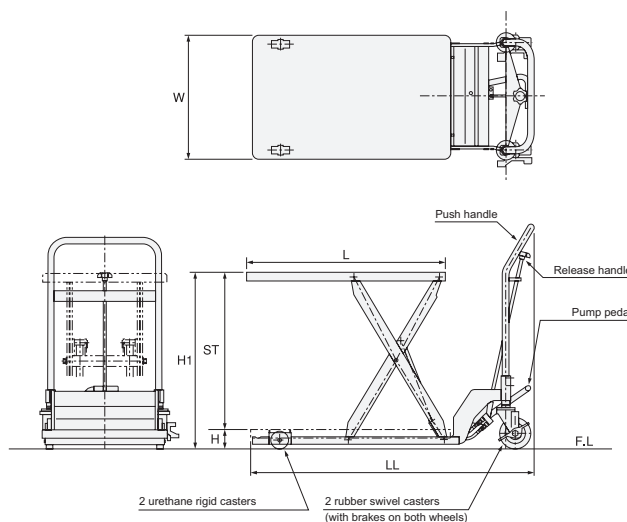

During lowering



Unit: inch

	Model	Load capacity	Table dimensions W x L	Stroke (ST)	Table height (H to H1)	Overall length (LL)	Wheel dimensions		Number of pump steps	Deadweight
							Rigid caster	Swivel casters with brakes		
Low platform	HLH-100-80L	221 lb	15.8×28.4	21.9	3.2 to 25	40.2	φ3	φ3.9	Approx. 14 times	77 lb
	HLH-200-80L	441 lb	19.7×31.5	24.8	3.2 to 28	44.9	φ3	φ4.9	Approx. 42 times	126 lb

• The swivel casters have rubber wheels and the rigid casters have urethane wheels. • HLH-100-80L has rubber wheels.